

# LINED VALVE COMPANY, INC.

---

## FIGURE 65 URETHANE LINED DUCTILE IRON BODY KNIFE GATE VALVE

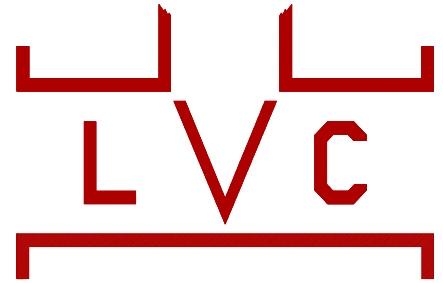

## FEATURES

---

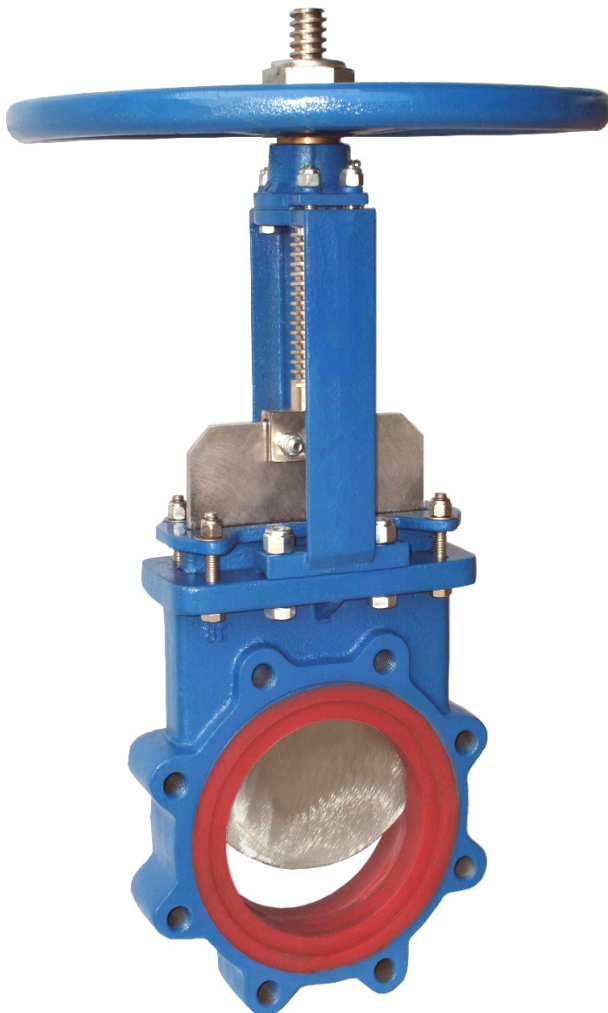

- **HEAVY DUTY** cast ductile iron body and yoke for the most rugged service.
  - **HEAVY DUTY** Lug body design.
  - **URETHANE LINER** and seat provides a **BI-DIRECTIONAL BUBBLE TIGHT SEAL** across gate from 0 to 150 PSI.
  - **SEAT IS FLUSH** with the bottom of the port **ELIMINATING** any pockets in the bottom of the Valve to collect material in media such as slurries, pellets or powders.
  - **URETHANE LINER** is a one piece molded in place full body liner with integral seat.
  - Urethane liner can be replaced by the manufacturer.
  - **STAINLESS STEEL GATE and STEM** for corrosion resistance and durability.
  - **EASY CONVERSION** from handwheel operator to cylinder, bevel gear or electric motor operator using cast yoke.
  - **ENCLOSED BRASS STEM BUSHING** provides reduced operating torque and protection of the stem bushing from harsh environments.
  - **FULL PACKING SEAL** around gate to minimize packing leakage.
  - **MSS-SP-81** face to face dimension and flange dimensions.
  - **FULL PORT ID.**
-

# LINED VALVE COMPANY, INC.

## DUCTILE IRON BODY URETHANE LINED - KNIFE GATE VALVE

### MATERIALS OF CONSTRUCTION

MODEL	65
1 GATE	SS
2 BODY	DI
3 SEAT	URETHANE
4 BOLTS	PLATED
5 PACKING	TLSP*
6 GLAND	DI
7 STEM	SS
8 YOKE	DI
9 STEM NUT	BRASS
10 HANDWHEEL	DI

\*TLSP = TFE Lubricated Synthetic Packing

Normally supplied with handwheel for manual operation, but can be modified for lever, chainwheel, bevel gear, electric motor, spring, hydraulic or pneumatic cylinder.

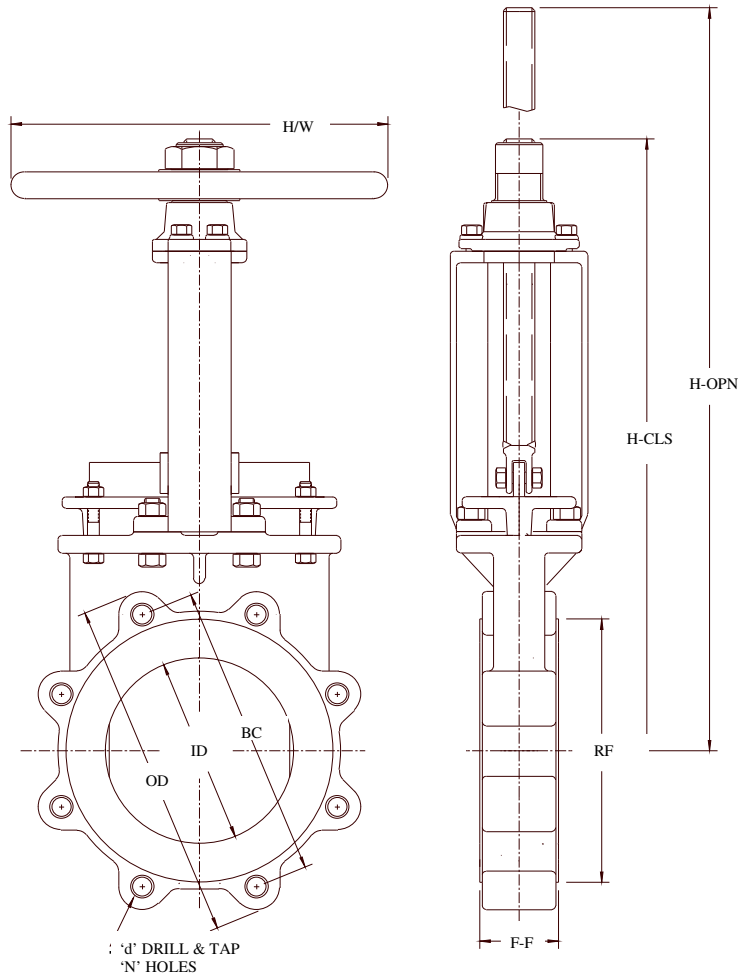

SEAT

### DIMENSIONS (INCHES) AND WEIGHTS

SIZE		3"	4"	6"	8"	10"	12"	14"	16"	18"		
FACE TO FACE	F-F	2"	2"	2-1/4"	2-3/4"	3"	3"	3-1/2"	3-1/2"	4-1/2"	4-1/2"	
FLANGE OD	OD	7-1/2"	9"	11"	13-1/2"	16"	19"	21"	23-1/2"	25"	27-1/2"	32"
BOLT CIRCLE	BC	6"	7-1/2"	9-1/2"	11-3/4"	14-1/4"	17"	18-3/4"	21-1/4"	22-3/4"	25"	29-1/2"
INSIDE DIAMETER	ID	3"	4"	6"	8"	10"	12"	13-1/4"	15-1/4"	17-1/4"	19-1/4"	23-1/4"
NUMBER OF HOLES	N	4	8	8	8	12	12	12	16	16	20	20
HOLE D&T SIZE	d	5/8"-11	5/8"-11	3/4"-10	3/4"-10	7/8"-9	7/8"-9	1"-8	1"-8	1-1/8"-7	1-1/8"-7	1-1/4"-7
C/L TO TOP-CLOSED	H-CLS	14-1/4"	16-1/4"	20-1/8"	24-1/4"	28-1/2"	34-1/2"	40"	41"	47"	51-3/4"	58-3/4"
C/L TO TOP-OPEN	H-OPN	17-1/2"	20-1/2"	26-1/2"	32-1/2"	38-3/4"	47"	54-1/4"	56-1/4"	64"	72-1/4"	82-1/4"
HANDWHEEL DIA.	H/W	8"	12"	12"	16"	16"	16"	24"	24"	24"	24"	24"
WEIGHT - LBS.		29	38	52	85	120	160	212	300	350	480	600

**LINED VALVE COMPANY**  
 675 Mitchell Avenue  
 Woodland, WA 98674  
 E-mail: sales@linedvci.com



Tel: 360-225-1230  
 888-256-5779  
 Fax: 360-225-1235  
 WEB SITE: www.knifegatevalves.com