

LINED VALVE COMPANY, INC.

FIGURE 77 STAINLESS STEEL RUBBER SEATED KNIFE GATE VALVE

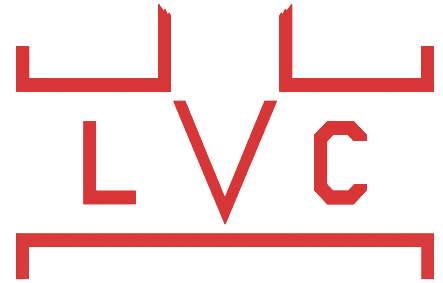

FEATURES

- **Cast Stainless Steel** body, packing gland and yoke.
 - **Precision machined stainless steel gate** for superior seating capability.
 - **Gate designed to** withstand **full 150 PSI** rated pressure as required by MSS-SP-81.
 - Rubber Seat provides a **BI-DIRECTIONAL DRIP TIGHT SEAL** across the gate from 0 to 150 PSI.
 - **Heavy duty designed body** to resist deflection from line loads and internal pressure.
 - **Rubber seat is flush with the bottom** of the port **ELIMINATING any pockets** in the bottom of the valve that will collect media material.
 - **Rubber seat replacement is quick and easy.**
 - **Heavy duty cast stainless steel yoke** will not bend or twist under extreme loads.
 - **Easy conversion** from handwheel operator to cylinder, bevel gear or electric motor operator using cast yoke.
 - **Enclosed brass stem bushing** provides reduced operating torque and protection of the stem bushing from harsh environments.
 - **Stainless steel stem** for corrosion resistance.
 - **Designed and tested to MSS-SP-81** dimensions and specifications.
 - **Full port ID.**
 - **TFE lubricated synthetic packing (TLSP)** rated for 400 F with a PH range of 3-11 is standard.
-

LINED VALVE COMPANY, INC.

CAST STAINLESS STEEL - RUBBER SEAT - KNIFE GATE VALVE

MATERIALS OF CONSTRUCTION		
MODEL		77
1 GATE		SS
2 BODY		SS
3 SEAT		Hycar
4 BOLTS		SS
5 PACKING	TLSP*	
6 GLAND		SS
7 STEM		SS
8 YOKE		SS
9 STEM NUT	BRASS	

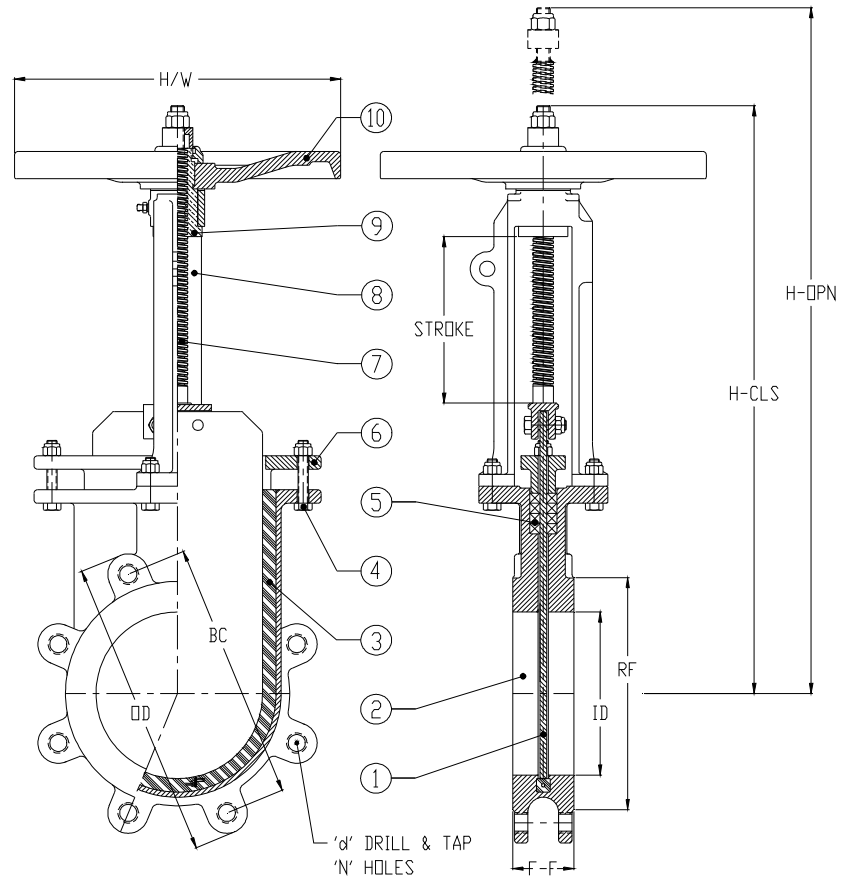

*TLSP = TFE Lubricated Synthetic Packing

Stocked in 316 SS. 317 SS Available.

Normally supplied with handwheel for manual operation, but can be modified for lever, chainwheel, bevel gear, electric, hydraulic cylinder or pneumatic cylinder operator.

SEAT MATERIALS AVAILABLE:
 HYCAR HYPALON
 EPDM

DIMENSIONS (INCHES) AND WEIGHTS

SIZE		2"	3"	4"	6"	8"	10"	12"	14"	16"	18"	20"	24"
FACE TO FACE	F-F	1-7/8"	2"	2"	2-1/4"	2-3/4"	2-3/4"	3"	3"	3-1/2"	3-1/2"	4-1/2"	4-1/2"
FLANGE OD	OD	6"	7 1/2"	9"	11"	13-1/2"	16"	19"	21"	23-1/2"	25"	27-1/2"	32"
BOLT CIRCLE	BC	4-3/4"	6"	7-1/2"	9-1/2"	11-3/4"	14-1/4"	17"	18-3/4"	21-1/4"	22-3/4"	25"	29-1/2"
INSIDE DIAMETER	ID	2"	3"	4"	6"	8"	10"	12"	13-5/8"	15-1/2"	17-1/5"	19-1/2"	23-3/8"
NUMBER OF HOLES	N	4	4	8	8	8	12	12	12	16	16	20	20
HOLE D&T SIZE	d	5/8"-11	5/8"-11	5/8"-11	3/4"-10	3/4"-10	7/8"-9	7/8"-9	1"-8	1"-8	1-1/8"-7	1-1/8"-7	1-1/4"-7
C/L TO TOP-CLOSED	H-CLS	13-5/8"	16"	17-3/4"	21-5/8"	26-3/4"	32-1/8"	36-3/8"	42"	46-3/4"	52-3/8"	55-3/4"	66-1/2"
C/L TO TOP-OPEN	H-OPN	16"	19-3/4"	21-5/8"	27-3/4"	34-3/4"	42-3/4"	48-5/8"	55-1/4"	63-1/8"	70-1/2"	76-3/4"	85-3/4"
HANDWHEEL DIA.	H/W	8"	8"	8"	12"	12"	15"	15"	15"	20"	20"	20"	30"
WEIGHT - LBS.		20	29	38	52	85	120	160	212	300	350	480	600

LINED VALVE COMPANY, INC
 675 MITCHELL AVE.
 WOODLAND, WA 98674

WEB SITE: www.knifegatevalves.com
 TEL: 360-225-1230
 FAX: 360-225-1235