

LINED VALVE COMPANY, INC.

FIGURE 53 DUCTILE IRON KNIFE GATE VALVE

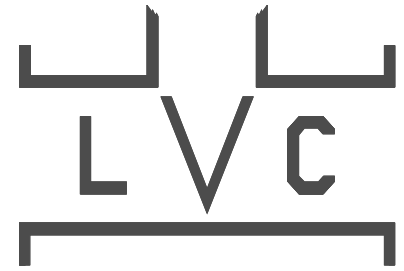

FEATURES



- **HEAVY DUTY** cast ductile iron body and yoke for the most rugged service.
 - Through bolting on side flange bolts to allow easy installation.
 - Replaceable natural rubber seat provides a **BI-DIRECTIONAL BUBBLE TIGHT SEAL** across gate from 0 to 150 PSI.
 - Rubber seat is flush with the bottom of the port **ELIMINATING** any pockets in the bottom of the Valve to collect material in media such as slurries, pellets or powders.
 - Rubber seat has a **molded-in steel reinforcement** and is bolted in place to prevent it from being shifted out of position by gate movement.
 - Rubber seat replacement is quick and easy.
 - Machined stainless steel gate for corrosion resistance and durability.
 - Stainless steel stem for corrosion resistance.
 - Easy conversion from handwheel operator to cylinder, bevel gear or electric motor operator using cast yoke.
 - Enclosed **brass stem bushing** provides reduced operating torque and protection of the stem bushing from harsh environments.
 - Full packing seal around gate to prevent packing leakage.
 - **MSS-SP-81** face to face dimension and flange dimensions.
 - **Full port ID.**
 - Minimum 4 bolt packing gland to assure proper gland alignment in all valve sizes.
 - All ductile iron surfaces (**interior & exterior**) are coated with a **epoxy powder coating** for long lasting corrosion resistance.
-

**LINED VALVE COMPANY, INC.
CAST DUCTILE IRON KNIFE GATE VALVE - FIG 53**

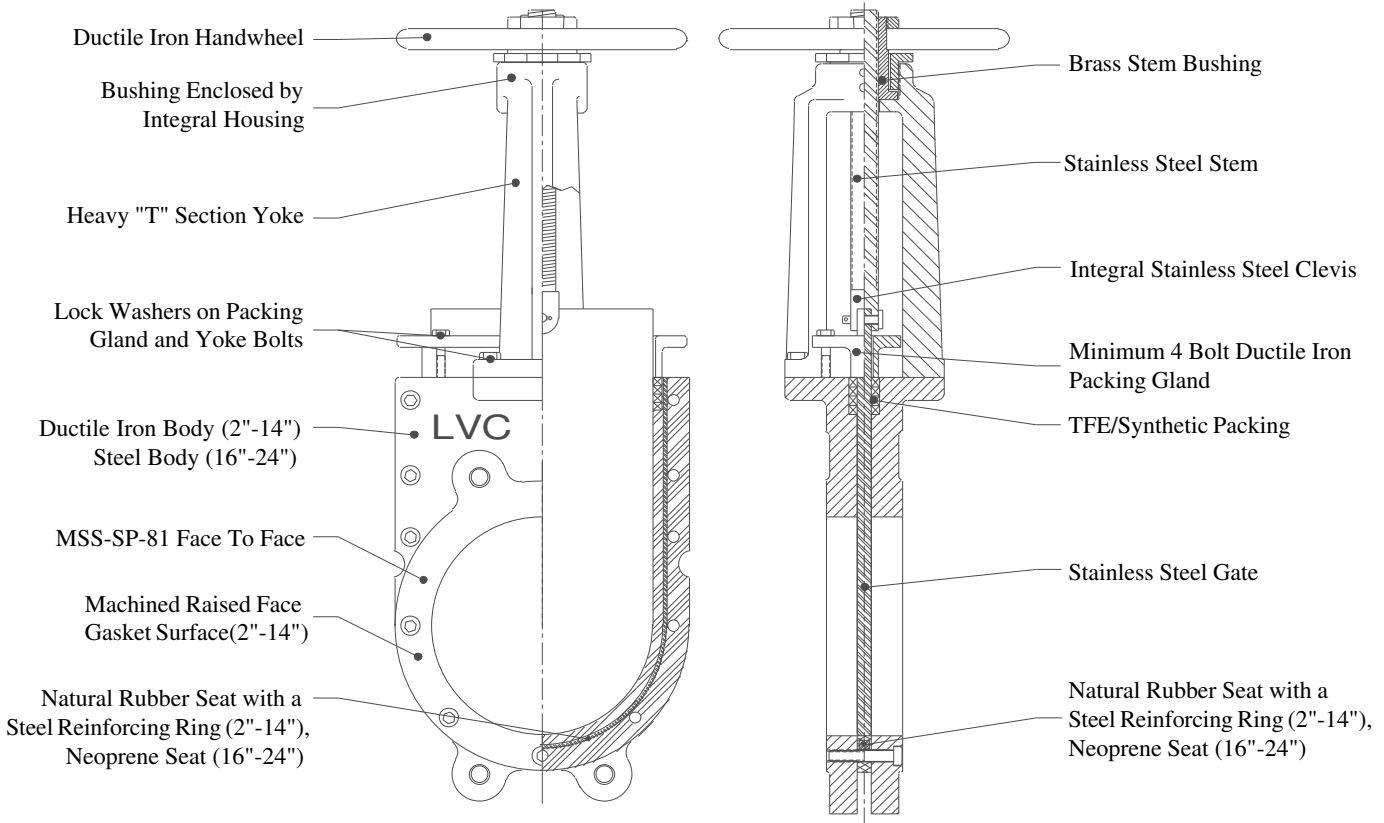

DIMENSIONS AND WEIGHTS:

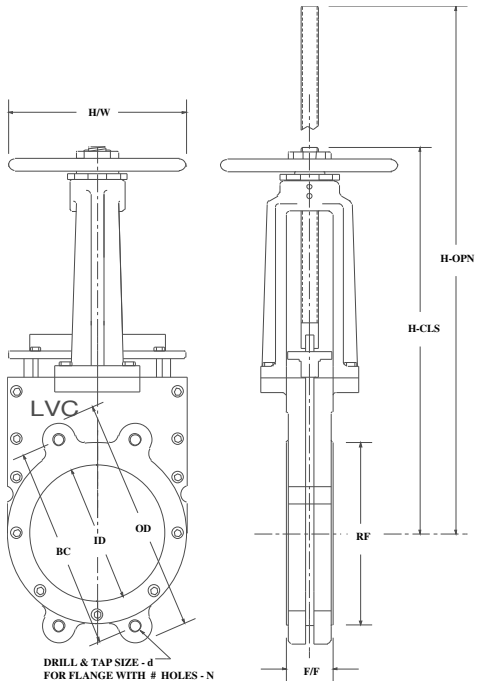

	VALVE SIZE											
	3"	4"	6"	8"	10"	12"	14"	16"	18"	20"	24"	
ID	3"	4"	6"	8"	10"	12"	14"	15-1/4"	17-1/4"	19-1/4"	23-1/4"	
F/F	2"	2"	2-1/4"	2-3/4"	2-3/4"	3"	3"	3-1/2"	3-1/2"	3-1/2"	3-7/8"	
BC	6"	7-1/2"	9-1/2"	11-3/4"	14-1/4"	17"	18-3/4"	21-1/4"	22-3/4"	25"	29-1/2"	
RF	5"	6-3/16"	8-1/2"	10-5/8"	12-3/4"	15"	16-1/4"	18-1/2"	-FLAT FACE FLANGE-			
OD	7-1/2"	9"	11"	13-1/2"	16"	19"	21"	23-1/2"	25"	27-1/2"	32"	
N	4	8	8	8	12	12	12	16	16	20	20	
d	5/8"-11	5/8"-11	3/4"-10	3/4"-10	7/8"-9	7/8"-9	1"-8	1"-8	1-1/8"-7	1-1/8"-7	1-1/4"-7	
H/W	8"	10"	12"	14"	16"	20"	24"	24"	24"	24"	24"	
H-CLS	14-1/4"	16-1/4"	20-1/8"	24-1/4"	28-1/2"	34-1/2"	40"	40-3/8"	47-3/8"	51"	60-1/2"	
H-OPN	17-1/2"	20-1/2"	26-1/2"	32-1/2"	38-3/4"	47"	54-1/4"	55-3/4"	64-1/2"	69"	82-3/4"	
WEIGHT	29	46	75	118	180	295	345	455	545	800	1050	

MATERIALS:

COMPONENT	MATERIAL (2"-14")	MATERIAL (16"-24")
BODY	CAST DUCTILE IRON	CARBON STEEL
GATE	STAINLESS STEEL	STAINLESS STEEL
PACKING GLAND	CAST DUCTILE IRON	CARBON STEEL
SEAT	NATURAL RUBBER	NEOPRENE
YOKE & RETAINER	CAST DUCTILE IRON	CARBON STEEL
STEM & CLEVIS	STAINLESS STEEL	STAINLESS STEEL
STEM BUSHING	BRASS	BRASS
BOLTING	PLATED	PLATED
PACKING	TFE/SYNTHETIC	TFE/SYNTHETIC

LINED VALVE COMPANY, INC.

675 MITCHELL AVE.
WOODLAND, WA 98675

TEL: 360-225-1230

FAX: 360-225-1235

F53CATA1 - 5/04

E-mail: lvc@linedvci.com