

# LINED VALVE COMPANY, INC.

---

## Fabricated Large Diameter Knife Gate Valves

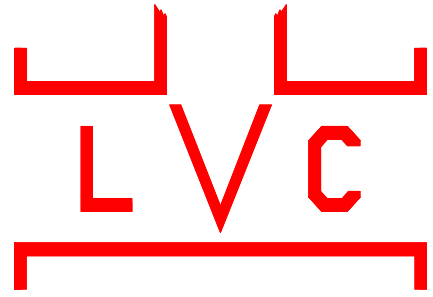

---

## FEATURES

---



- Offered in our series **F93** and **F79**
  - Fabricated **carbon steel** body flanges, packing gland and yoke.
  - All **Stainless steel** construction available
  - Fabricated **stainless steel liner**
  - **Stainless steel gate**
  - Stainless steel **metal to metal seat Fig. F93**
  - Bi-directional **resilient seat Fig. F79**
  - **Heavy duty** designed body to resist deflection from line loads and internal pressure.
  - Valves are designed for **50 PSI or 125 PSI CWP** pressure rating
  - Other pressure ratings available
  - Fig. F93's seat configuration and beveled gate designed to provide **shut-off** capability in thick media such as pulp stock, slurries, or with solid media such as pellets or powders.
  - **Heavy fabricated steel yoke** will not bend or twist under extreme loads.
  - **Easy conversion** from handwheel operator to cylinder, bevel gear or electric motor operator using existing yoke.
  - **Enclosed brass stem bushing** provides reduced operating torque and protection of the stem bushing from harsh environments.
  - O-Ring resilient seat available Fig. F93
  - **Precision machined** stainless steel gate for superior seating capability.
  - **Stainless steel stem** for corrosion resistance.
  - Sizes include 30", 36", 42", 48", 54", 60" or larger
  - **Bonneted** (Fig 193) versions are also available
-

# LINED VALVE COMPANY, INC

## FABRICATED STEEL KNIFE GATE VALVE—FIG F77 & F93

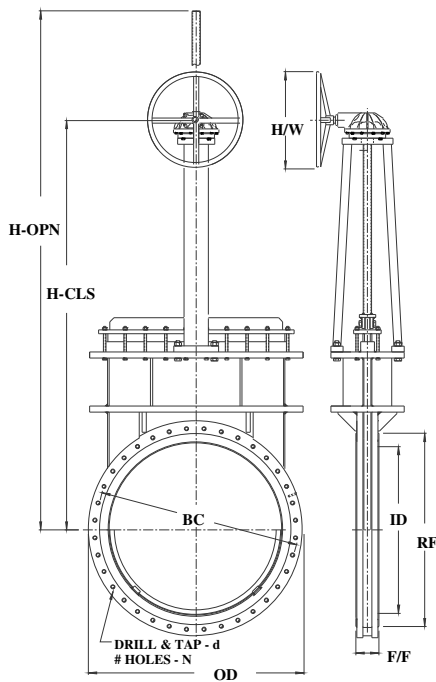
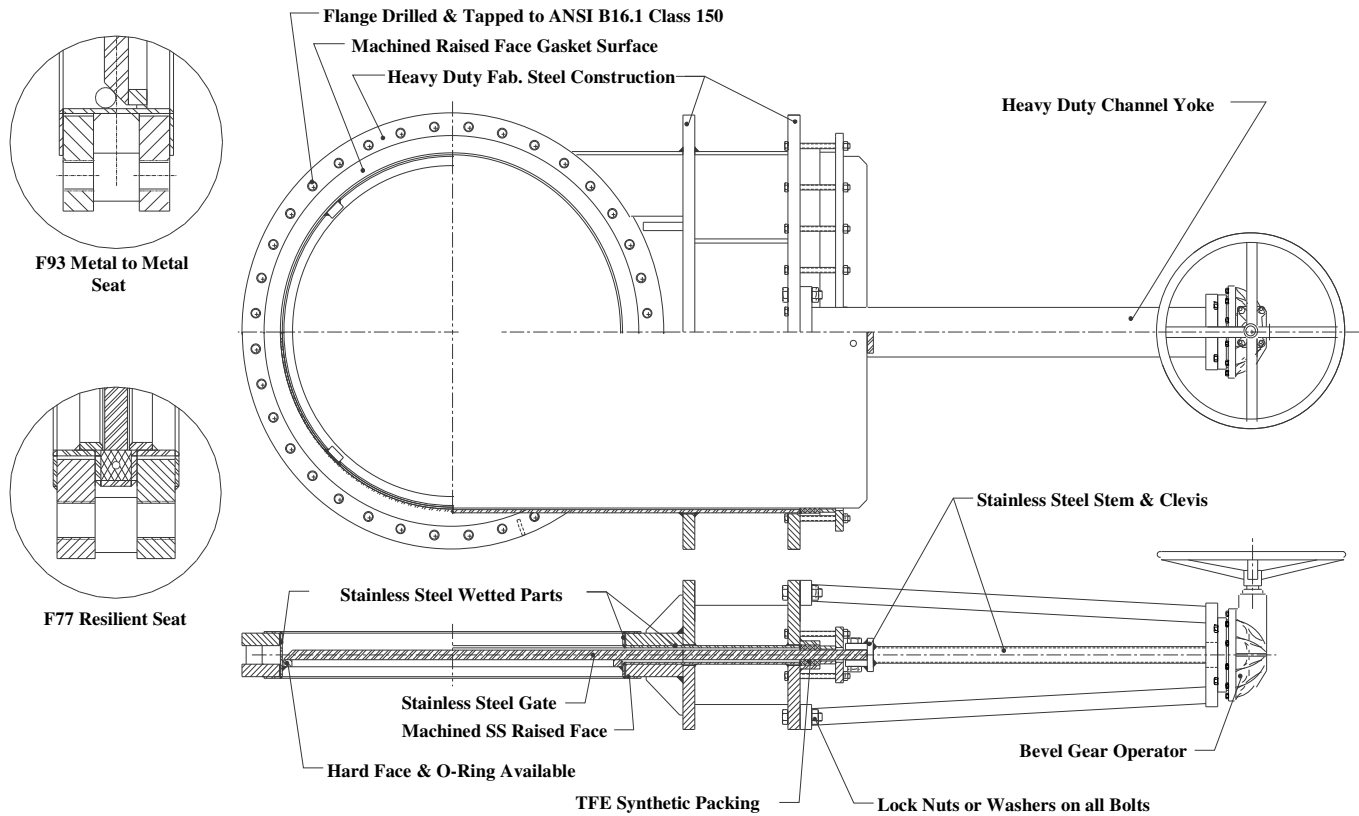

**DIMENSIONS:**

	VALVE SIZE									
	30"	30"	36"	36"	42"	42"	48"	48"	54"	60"
<b>ID</b>	28"	28"	33-3/4"	33-3/4"	40-1/2"	40-1/2"	46-1/2"	46-1/2"	52-1/2"	28-1/2"
<b>F/F</b>	4"	4-5/8"	5"	5-3/4"	5-5/8"	6-1/4"	6-1/8"	7"	6-5/8"	7"
<b>BC</b>	36"	36"	42-3/4"	42-3/4"	49-1/2"	49-1/2"	56"	56"	62-3/4"	69-1/4"
<b>RF</b>	33-3/4"	33-3/4"	40-1/4"	40-1/4"	47"	47"	53-1/2"	53-1/2"	59-1/2"	66"
<b>OD</b>	38-3/4"	38-3/4"	46"	46"	53"	53"	59-1/2"	59-1/2"	66-1/4"	73"
<b>N</b>	28	28	32	32	36	36	44	44	44	52
<b>d</b>	1-1/4"-7	1-1/4"-7	1-1/2"-6	1-1/2"-6	1-1/2"-6	1-1/2"-6	1-1/2"-6	1-1/2"-6	1-3/4"-5	1-3/4"-5
<b>H/W</b>	24"	24"	24"	24"	36"	36"	36"	36"	36"	36"
<b>H-CLS</b>	74-3/4"	74-3/4"	89-1/8"	89-1/8"	97-1/4"	97-1/4"	110"	110"	123"	135"
<b>H-OPN</b>	104"	104"	121"	121"	136"	136"	155"	155"	173"	189"
<b>PRESSURE RATING</b>	50 PSI	125 PSI	50 PSI	125 PSI	50 PSI	125 PSI	50 PSI	125 PSI	50 PSI	50 PSI

**MATERIALS:**

	MATERIAL CODE				
	W44	A44	W66	A66	A77
<b>BODY, SEAT* &amp; RF</b>	304	304	316	316	317
<b>GATE</b>	304	304	316	316	317
<b>PACKING GLAND</b>	STEEL	304	STEEL	316	317
<b>FLANGES, EXT TRIM</b>	STEEL	304	STEEL	316	317
<b>YOKE</b>	STEEL	304	STEEL	316	317
<b>STEM &amp; CLEVIS</b>	304	304	304	304	304
<b>STEM BUSHING</b>	BRASS	BRASS	BRASS	BRASS	BRASS
<b>BOLTING</b>	PLATED	304	PLATED	304	304
<b>PACKING</b>	TFE/SYN	TFE/SYN	TFE/SYN	TFE/SYN	TFE

\*STANDARD SEAT MATERIAL FOR F77 IS HYCAR. EPDM, NEOPRENE, AND VITON AVAILABLE

**LINED VALVE COMPANY, INC.**

675 Mitchell Ave.  
 Woodland, WA 98674

Tel: 360-225-1230

Fax: 360-225-1235

888-256-5779